

H.R. UV-C SPA

Using the latest amalgam lamp technology, the small, yet powerful H.R. UV-C Spa, offers the highest possible performance over a wide range of temperatures with a consistent output of UVC.

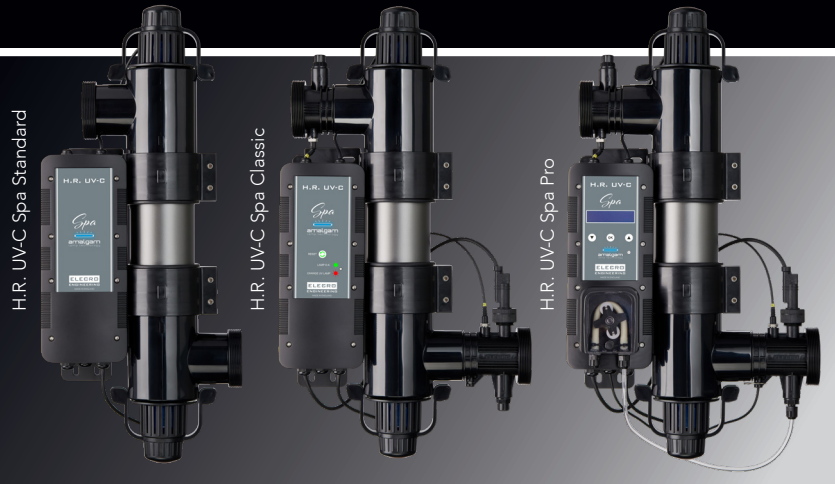

FEATURES

- Highest UV reflective index on the market equating to supreme efficiency
- E-PTFE reaction chamber is extremely repellent, maintaining UV reflectivity
- Up to 95% reflection amplifying the exposure of microorganisms to UV
- No harmful gases or by-products produced
- Neutralises bacteria, viruses, algae and fungi that traditional chemicals cannot
- Optional smart peristaltic dosing system for chlorine/hydrogen peroxide (Pro model only)
- Powerful sterilisation and eliminates the smell of chlorine

- Average lamp life expectancy: 2 years
- Equipped with intelligent lamp life indicator (Classic & Pro models only)
- Sea and salt-chlorinated water compatible
- Models: Standard, Classic and Pro

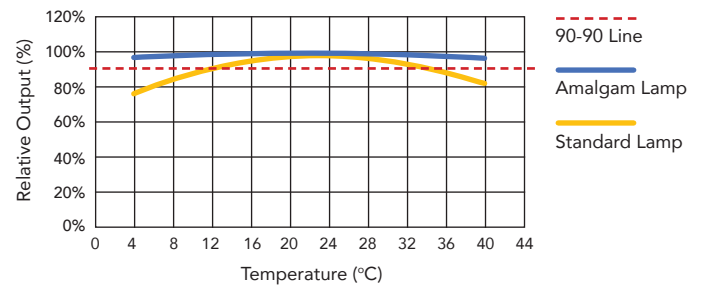

TECHNICAL DRAWINGS

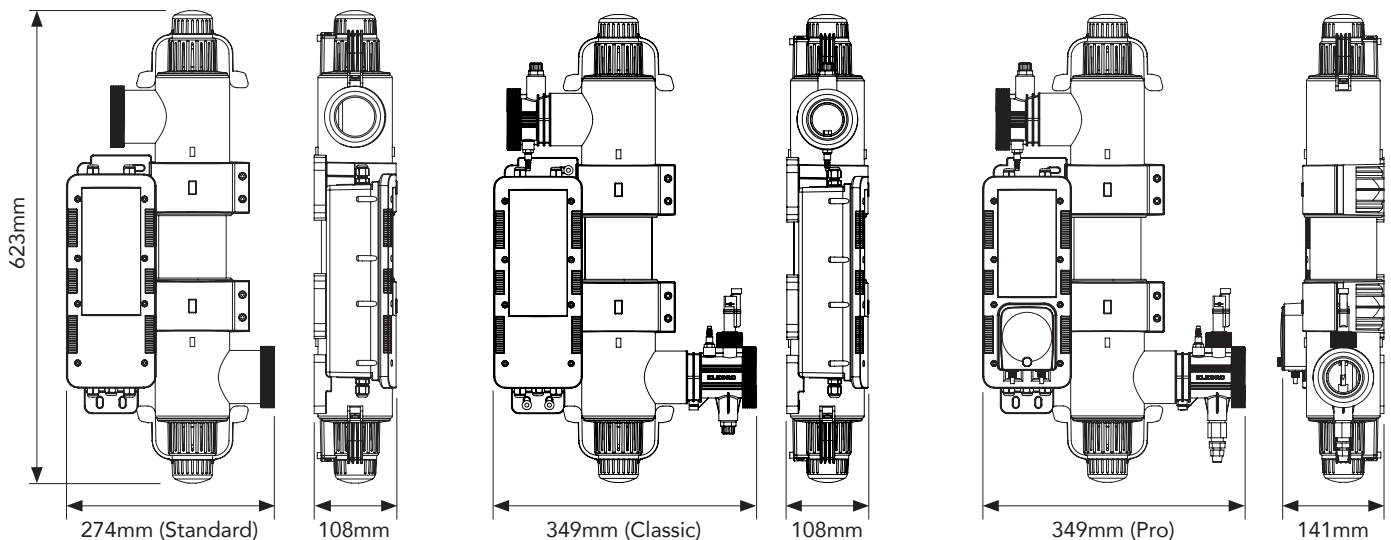

SYSTEM SETUP

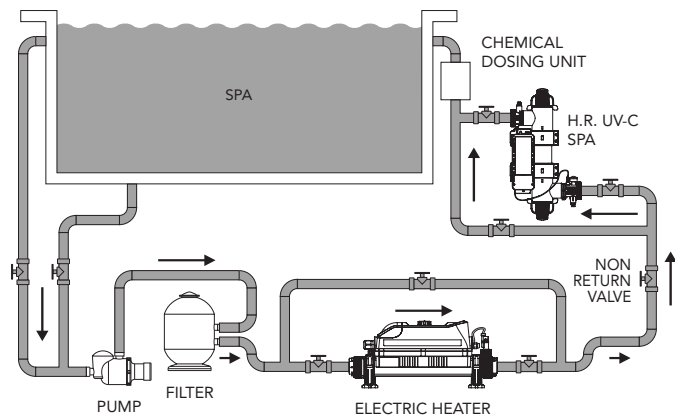

PRESSURE DROP

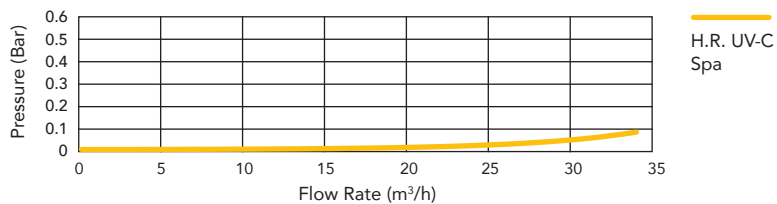

SPECIFICATIONS

Power supply:	Single Phase 100 ~ 240V
Min. flow rate:	1.5m³/h
Max. flow rate:	12,000 litres per hour; 12m³/h
Max. spa size:	30,000 litres; 30m³
Max. power consumption:	40W
Lamp:	Amalgam
Lamp life:	14,000 hours
Dosing rate:	Exceeds the equivalent of 30mj/cm² at maximum flow rate

Ingress protection rating:	IP64
Frequency:	50/60 Hz
Working pressure:	3 Bar maximum
Water connections:	2"/63mm stepped ABS unions + reducers 1½"/50mm
Salt water:	100% chlorinated salt and sea water safe
Mounting:	Vertical or horizontal wall mounting
Oxidisation processes:	UV

MODELS

100~240V 1-PHASE	LAMP OUTPUT (W)	MAX. POOL VOL (m³)*	FEATURES	NET WEIGHT (kg)	GROSS WEIGHT (kg)	GROSS VOL (m³)	NO PLUG	PRODUCT CODE**			
								UK PLUG	EURO PLUG	USA PLUG	
Spa Standard	30	30	Standard features	4.5300	6.0600	0.0639	HR-30-B-SPA	-	-	-	
Spa Classic	30	30	Flow switch, analogue lamp life indicator & reset switch	4.8300	6.7000	0.0639	-	HR-30-UK-SPA	HR-30-EU-SPA	HR-30-USA-SPA	
Spa Pro	30	30	Flow switch, digital lamp life countdown & intelligent dosing pump	5.4300	7.3000	0.0639	-	HRP-30-UK-SPA	HRP-30-EU-SPA	HRP-30-USA-SPA	

*Minimum filtration turnaround of three times per day. **For other plug types, please contact our sales team at sales@elecro.co.uk

